

## Chapter 2

# Ultrasonics

### 2.1 Introduction

- Ultrasonic:  $> 20$  KHz ( $>$  Audible limit, typically a few MHz).
- Ultrasonics techniques are concerned with very high frequencies to avoid confusion with background noise.
- Sound waves propagate well in metal and poorly in air.
- Ultrasonics rely on pulses of energy generated by an external source (transmitter).
- Modification is by the material between the source and the sensor.
- Back reflection (echo) is most common technique.
- Need to study wave propagation in matter.

### 2.2 Physics of Acoustic Waves

**Compression Waves:** Longitudinal in 1-D, Dilational in 3-D.

**Shear Waves:** Transverse in 1-D, Torsional in 3-D.

**Surface Waves:** Raleigh waves.

**Plate Waves:** Lamb Waves.

To study above waves let us consider first 1-D waves.

### 2.2.1 1-D Plane Waves

- Consider a bar of length  $L$  supported by frictionless supports.
- Introduce an impulse disturbance at one end of the bar (rifle bullet, hammer, electrical spark, laser pulse, piezoelectric transducer, or a shove with the hand).
- A shove by hand will simply make the bar oscillate, with no relative motions between the ends.
- A tap with a small hammer: there will be a period in which the left face will have moved, while the right face remains undisturbed.
- Then, there will be an *elastic deformation*.

NDT requires small disturbance:

$$\begin{aligned}
 \xi + d\xi &= \xi + \frac{\partial \xi}{\partial x} dx + \text{H.O.T.} = \xi + \frac{\partial \xi}{\partial x} dx \\
 \Delta l &= \text{change in length of element} \\
 \delta l &= (\xi + d\xi) - \xi = \frac{\partial \xi}{\partial x} dx \\
 \Delta \epsilon &= \frac{\Delta l}{\Delta x} \\
 &= \frac{(\partial \xi / \partial x) dx}{dx} = \frac{\partial \xi}{\partial x}
 \end{aligned} \tag{2.1}$$

$$\begin{aligned}
 dF_x &= \left( F_x + \frac{\partial F_x}{\partial x} dx \right) - F_x \\
 &= \frac{\partial F_x}{\partial x} dx
 \end{aligned} \tag{2.2}$$

**Hook's Law for an elastic Material**

$$\begin{aligned}
 E &= \frac{\Delta \sigma}{\Delta \epsilon} \\
 \Delta \sigma &= \frac{F_x}{A} \\
 F_x &= AE \frac{\partial \xi}{\partial x} \\
 \Delta \epsilon &= \frac{\partial \xi}{\partial x} \\
 \frac{\partial F_x}{\partial x} &= AE \frac{\partial^2 \xi}{\partial x^2} \\
 dF_x &= AE \frac{\partial^2 \xi}{\partial x^2} dx
 \end{aligned} \tag{2.3}$$

Force = mass  $\times$  acceleration

$$\begin{aligned}
 F &= m \times a \\
 dF_x &= dm \times a \\
 a &= \frac{\partial^2 \xi}{\partial t^2} \\
 dm &= \rho \times A \, dx \\
 dF_x &= \rho A \frac{\partial^2 \xi}{\partial t^2} \, dx
 \end{aligned}
 \tag{2.4}$$

Equating the two equations for  $dF_x$ , one obtains the Wave Equation:

$$\frac{\partial^2 \xi}{\partial t^2} = \frac{E}{\rho} \frac{\partial^2 \xi}{\partial x^2}
 \tag{2.5}$$

$C_l = \sqrt{\frac{E}{\rho}}$  = speed of travel of stress wave in medium.

**Elastic Constants**

$$\begin{aligned}
 E &= \frac{\mu(3\lambda+2\mu)}{\lambda+\mu} = \text{Young's Modulus} \\
 \nu &= \frac{\lambda}{2(\mu+\lambda)} = \text{Poisson's Ratio} \\
 k = G &= \frac{3\lambda+2\mu}{3} = \text{Bulk Modulus}
 \end{aligned}
 \tag{2.6}$$

### 2.2.2 Plane Longitudinal Waves

1-D compressive waves:

- Particle motion is oriented parallel to the direction of travel (wave propagation).
- Can travel in solids, liquids and gases.
- Speed:

$$\begin{aligned}
 C_l &= \sqrt{\frac{E}{\rho}} = \left[ \frac{E(1-\nu)}{\rho(1+\nu)(1-2\nu)} \right]^{\frac{1}{2}} \\
 \mu &= \text{Shear modulus, Lamé constant} \\
 E &= \text{Modulus of Elasticity} \\
 \nu &= \text{Poisson's Ratio} \\
 \rho &= \text{Material density}
 \end{aligned}
 \tag{2.7}$$

### 2.2.3 Plane Transverse Waves

- Particle motion is oriented  $\perp$  direction of motion.
- Can only travel in solids, but not in gases or liquids.
- Speed:

$$C_t = \sqrt{\frac{\mu}{\rho}} = \left[ \frac{E}{2\rho(1+\nu)} \right]^{1/2} \quad (2.8)$$

- $C_t > C_l$ , by a factor 1.5 for most materials

### 2.2.4 Bulk Waves

- Particle is not restricted to one direction.
- *Dilational Wave*: analogous to longitudinal

$$\begin{aligned} \frac{\partial^2 \xi}{\partial t^2} &= C_1^2 \nabla^2 \vec{\theta} \\ \vec{\theta} &= \frac{\partial \xi}{\partial \vec{r}} \\ \vec{\theta} &= \text{vector notation of dilational motion of wave front} \\ \vec{r} &= \text{direction of motion} \\ C_1 &= \sqrt{\frac{\lambda+2\mu}{\rho}} \end{aligned} \quad (2.9)$$

- *Torsional Wave*

$$\begin{aligned} \frac{\partial^2 \xi}{\partial t^2} &= C_2^2 \nabla^2 \vec{\xi} \\ \vec{\xi} &= \text{vector notation of dilational motion of torsional wave} \\ C_2 &= \sqrt{\frac{\mu}{\rho}} \end{aligned} \quad (2.10)$$

### 2.2.5 Surface Waves

- Particles vibrate near the surface of a solid of weakly bonded molecules.
- Particles move  $\perp$  to the surface in an elliptical motion.
- Similar to wave left on surface of a still pond when a peddle is dropped into it.
- Equation of fundamental wave:

$$R_r^6 - 8R_r^4 + (24 - 16T_r^2)R_r^2 + 16(T_r^2 - 1) = 0 \quad (2.11)$$

where  $R_r = C_R/C_2$ ,  $T_r = C_2/C_1 = 0.5(1 - 2\nu)/(1 - 2\nu)$ , where  $C_R$  is the speed of Rayleigh wave;  $C_R \approx 0.9C_2$  for most metals; note  $R_r = C_R/C_2$  is a function of  $\nu$ , so is  $C_2/C_1$ ; for steel  $\nu = 0.29$ , copper  $\nu = 0.34$ , aluminum  $\nu = 0.34$ .

- Depth of penetration of the Rayleigh wave increases with increasing  $\nu$ .
- $C_R$  changes with  $r/\lambda$ , where  $\lambda$  is wavelength and  $r$  is surface radius of curvature.
- If  $r \gg \lambda$ , speed does not change, as is the case with a flat surface; then  $R_r \approx 0$  and  $T \approx 1$ .
- As  $r/\lambda$  decreases, e.g. at sharp corners, speed increased and  $R_r$  increases.
- At  $r/\lambda = 2.5$ ,  $C_R$  approaches  $C_2$ , i.e. wave approaches a shear wave; at  $r/\lambda = 0.7$ ,  $C_R = 1.28C_2$ .
- At  $r/\lambda = 0.5$ , wave becomes erratic due to phase difference as the transmitted and reflected half-waves fit into the rounded arc.

### 2.2.6 Lamb Waves

- Travel in thin material, i.e. plates, where thickness  $\approx$  wavelength.
- Speed is determined by material density, frequency and wave type.
- Plate functions as a waveguide.
- Used in inspection of metal for horizontal separation.

## 2.3 Modification

### 2.3.1 Specific Acoustic Impedance

Particle displacement,  $\xi$ , due to a 1-D wave propagating in the  $x$  direction, can be described by a simple harmonic (oscillatory) motion as:

$$\xi = A \exp\{j(\omega t - kx + \phi)\} = A \exp\{2\pi j(\frac{t}{T} - \frac{x}{\lambda} + \phi)\} \quad (2.12)$$

where  $A$  is the wave amplitude,  $\omega = 2\pi f$ ,  $T = 1/f$ ,  $f$  is wave frequency,  $k = 2\pi/\lambda = \omega/C$  is wave number,  $C = \lambda f$  is wave speed,  $\phi$  is initial phase shift.

- Pressure due to wave in an elastic material:  $p = E \frac{\partial \xi}{\partial x}$ .
- Velocity of displacement:  $u = \frac{\partial \xi}{\partial t}$ .
- Specific Acoustic Impedance:  $Z = p/u = -E(k/\omega)$ .
- For a longitudinal wave:  $|Z| = E/C_l = \rho C_l^2 / C - 1 = \rho C_l$ .
- Material is defined acoustically by value of  $Z$ .
- in NDT we are looking for a change, which is reflected by change of  $Z$  along the wave direction.

### 2.3.2 Reflection and Transmission Coefficients

When a wave encounters a change in  $Z$ , i.e. an interface, wave can be: transmitted, reflected or refracted. It can also change mode. These changes affect the amplitude, pressure and power of wave. We will examine these changes in normal and oblique wave incidence.

#### Normal Incidence

As wave crosses a surface from a medium with  $Z = Z_1$  to another with  $Z =$

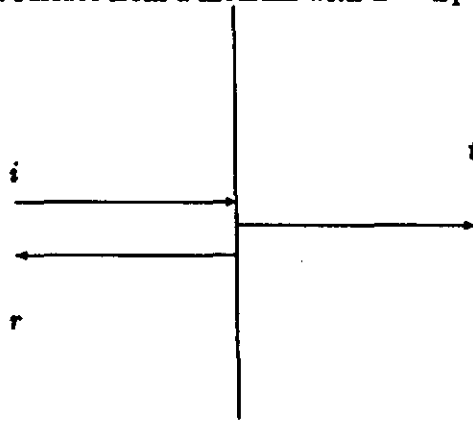

$Z_2$ , two conditions must be maintained:

**Equilibrium:** Force on one side of object is equal to that on the other side, leading to:

$$F_i = F_t - F_r \quad (2.13)$$

where  $F$  designates force and the subscripts  $i$ ,  $r$ , and  $t$  designate, respectively, the incident, reflected and transmitted waves. Keeping

in mind that the area changes sign from one side to the other, then  $P_i = +F_i/(-\text{Area})$ ,  $P_r = -F_r/(-\text{Area})$  and  $P_t = +F_t/(+\text{Area})$ , where  $P$  designates the magnitude of the pressure at the interface. This leads to:

$$P_t = P_i + P_r \quad (2.14)$$

**Continuity:** Particle has to continue moving at same velocity, i.e.

$$U_t = U_i - U_r \quad (2.15)$$

where  $U$  designates the magnitude of velocity at the interface. Now at the interface:

$$Z_2 = \frac{P_t}{U_t} = \frac{P_i + P_r}{U_i - U_r} = \frac{P_i + P_r}{P_i/Z_1 - P_r/Z_1} = \frac{1 + R}{1 - R} Z_1 \quad (2.16)$$

where  $R$  is the *pressure reflection coefficient*. Then:

$$R = \frac{Z_2 - Z_1}{Z_1 + Z_2} \quad (2.17)$$

Similarly, for *pressure transmission coefficient*,  $T$ ,

$$T = \frac{P_t}{P_i} = \frac{P_i + P_r}{P_i} = 1 + \frac{P_r}{P_i} = 1 + R = \frac{2Z_1}{Z_1 + Z_2} \quad (2.18)$$

Note that  $R + T \neq 1$ , but  $R - T = 1$ . Why?

**Amplitude Coefficients:**

$$R_A = \frac{A_r}{A_i} = \frac{k_1 E_1 A_r}{k_1 E_1 A_i} = \frac{P_r}{P_i} = R \quad (2.19)$$

$$T_A = \frac{A_t}{A_i} = \frac{P_t/(k_2 E_2)}{P_i/(k_2 E_2)} = T \frac{k_1 E_1/\omega}{k_2 E_2/\omega} = T \frac{Z_1}{Z_2} = \frac{2Z - 1}{Z_1 + Z_2} \quad (2.20)$$

Note that here  $R_A + T_A = 1$ . Why?

**Power Coefficients:**

$$\begin{aligned} \text{Power per unit area at wave front} &= Pwr = 0.5 \times \text{stress} \times \text{strain} \times \frac{\partial x}{\partial t} \\ &= 0.5E \times \text{strain}^2 \times \frac{\partial x}{\partial t} = 0.5E \times \left(\frac{\partial \xi}{\partial x}\right)^2 \frac{\partial x}{\partial t} \\ &= 0.5 \times E \frac{\partial \xi}{\partial x} \frac{\partial \xi}{\partial t} = 0.5E(kA)(A\omega) = 0.5 \frac{EA^2\omega^2}{C_l} = 0.5ZA^2\omega^2 \end{aligned} \quad (2.21)$$

Then

$$R_{Pwr} = \frac{Pwr_r}{Pwr_i} = \frac{Z_1 A_r^2}{Z_1 A_i^2} = R_A^2 = R^2 \quad (2.22)$$

$$T_{Pwr} = \frac{Pwr_t}{Pwr_i} = \frac{Z_2 A_t^2}{Z_1 A_i^2} = \frac{Z_2 T_A^2}{Z_1} = \frac{4Z_1 Z_2}{(Z_1 + Z_2)^2} \quad (2.23)$$

Note that here  $R_{Pwr}^2 + T_{Pwr}^2 = 1$ . Why?

### Oblique Incidence

**Incident Wave:** Longitudinal, at angle  $\theta_1$  with normal to interface, in medium #1, with speed  $C_1$ .

**Reflected Wave:** Longitudinal, at angle  $\theta_1'$  with normal to interface, in medium #2, with speed  $C_1'$ .

**Reflected Wave:** Transverse, at angle  $\theta_2'$  with normal to interface, in medium #2 ( $\theta_1' > \theta_2'$ ), with speed  $C_2'$ .

**Refracted Wave:** Longitudinal, at angle  $\theta_1''$  with normal to interface, in medium #1, with speed  $C_1$ .

**Refracted Wave:** Transverse, at angle  $\theta_2''$  with normal to interface, in medium #1 ( $\theta_1'' > \theta_2''$ ), with speed  $C_2$ .

**Snell's Law:** In a homogeneous isotropic solid:

$$\frac{\sin \theta_1}{C_1} = \frac{\sin \theta_1'}{C_1'} = \frac{\sin \theta_2'}{C_2'} = \frac{\sin \theta_1''}{C_1} = \frac{\sin \theta_2''}{C_2} \quad (2.24)$$

Therefore:  $\theta_1'' = \theta_1$ .

**Normal Incidence:**  $\theta_1 = 0$ , then no transverse waves are generated and the refracted wave becomes the longitudinal wave.

**First Critical Angle:** reached when  $\theta_1' = \pi/2$ . Beyond this angle longitudinal wave component disappear leaving only the shear component,  $C_2'$ .

**First Critical Angle:** reached when  $\theta_2' = \pi/2$ . Beyond this angle wave is concentrated on surface (Rayleigh wave).

**Reflection and Refraction Coefficients:** relationships exist to describe these coefficients, but they are more complex than the case of normal incidence.



### 2.3.3 Loss of Pulse Energy

Even in the absence of an interface, the energy of an acoustic pulse will be dispersed by absorption (mechanical energy converted to heat), and scattering (reflections at grain boundaries, small cracks and other nonhomogeneities, important when grain size is 1/10 wavelength or larger).

#### Attenuation

At far fields, away from interference near the source, the pulse pressure can be described by (not accounting for beam divergence):

$$P = P_0 \exp(-aL) \quad (2.25)$$

where  $L$  is distance from source,  $a$  is the attenuation coefficient and  $P_0$  is the pulse pressure at  $L = 0$ . Alternatively,

$$\text{Sound Pressure Level} = \text{SPL} = 20 \log_{10} \frac{P}{P_0} \text{ dB} \quad (2.26)$$

where the logarithm to base 10 is used to provide a larger quantity to deal with, called the Decibels (dB). Then one can define another attenuation coefficient,  $\alpha$  in dB/m as:

$$\alpha L = 20 \log_{10} \frac{P_2}{P_1} \quad (2.27)$$

where  $P_1$  and  $P_2$  are the pressure at two consequent stations separated by distance  $L$ .

## 2.4 Source/Sensor

### 2.4.1 Transducers

Piezoelectric transducers are commonly used to generate ultrasonic waves, as well as to detect it. Other less common methods include optical deflection and capacitive displacement.

- Piezoelectricity is electricity or electric polarity due to pressure (crystalline substance); simply a microphone.
- Convert electric energy to mechanical energy and verse-versa.
- Pressure on a piezoelectric transducer generates an electric signal (voltage).

- Usually made of ceramics (Barium Titanium, Lead Zirconate Titanium or Lead Metaniobate), which are most sensitive but their sensitivity decreases with times and are not suited at high temperatures.
- Quartz has low sensitivity, but maintains sensitivity for a long time and is hard and resists water.
- Most ceramic and crystalline materials lose their piezoelectric properties above a certain temperature known as the Curie temperature, as the solid change crystalline structure from symmetric to antisymmetric. This temperature limits the upper operating temperature of the probe.
- Waves are generated as pulses for approximately  $1 \mu\text{s}$  (1 to 10 cycles of vibration).

#### 2.4.2 Acoustic Equivalence

- A transducer consists of the ringing crystal and a backing (Tungsten/epoxy backing).
- When the transducer is applied on a test material of acoustic impedance,  $Z_1$ , one needs to match this impedance with that of the transducer material,  $Z_0$  and the backing material,  $Z_2$ .
- When an electric pulse field spike is applied on the transducer, impulses of opposite signs will be excited at each interface of the crystal.
- The resulting stress wave will travel back and forth within the crystal as the oscillations occur.
- The amplitudes of the reflected and transmitted waves are governed by the values if  $Z_1$  and  $Z_2$ .
- The backing material is introduced to dampen oscillations, which otherwise will be very severe.
- Maximum energy transfer between transducer and test material occurs when  $Z_0 = Z_1$ .
- A measure of the ringing ability of a transducer is:

$$Q = \frac{\text{energy stored in crystal}}{\text{energy lost per cycle of vibration}} = \frac{\pi}{2} \frac{Z_0}{Z_1 + Z_2} \quad (2.28)$$

- A high  $Q$  results in a longer crystal ringing and increased efficiency and sensitivity (as a sensor), but poor frequency resolution; Good resolution means that subsequent rings do not interfere with each other.

### 2.4.3 Electric Equivalency

- Transducer is represented by a capacitance,  $C_0$ . A varying capacitance, inductance,  $L$ , and resistance, are usually associated with it in parallel, together with a power source.
- Optimum oscillation at resonance frequency, when mechanical and electric frequencies are equal:

$$\frac{1}{2\pi} \sqrt{\frac{s}{M}} = \frac{1}{2\pi\sqrt{LC_0}} \quad (2.29)$$

where  $s$  is the mechanical stiffness of the transducer and  $M$  is its mass.

- Tuning is achieved by varying the inductance  $L$ .
- The varying resistance is used to adjust pulse height (amplitude).
- The varying capacitance is used to adjust signal attenuation (decay).
- The frequency of the transducer is rated at the peak frequency,  $f_p$ , i.e. the frequency at which the response of the transducer peaks.
- The frequency range is defined by the band width  $B = f_b - f_a$ , where  $f_a$  and  $f_b$  are the frequency at which the response of the probe reaches half its maximum power.
- The percentage bandwidth is defined as  $B^* = 100(f_b - f_a)/f_c$ .
- The central frequency is defined as  $f_c = 0.5(f_a + f_b)$ .
- The skewness of the response is defined as  $f_{skw} = (f_p - f_a)(f_b - f_p)$ ; ideally  $f_{skw} = 1$ .

### 2.4.4 Couplants

- Required to maximize energy transfer from transducer to test material.
- It also smooths surface irregularities and excludes air between surfaces.

- Immersion method: de-aerated water can act as a couplant, test specimen and transducer, contacted by a column of water or a wheel-filled with liquid.
- Contact materials placed between specimen and transducer include oil, grease, glycerin, honey, water, or thickened water (water gel).

### 2.4.5 Beam Spreading

- Waves produced from a finite-size transducer can be visualized as being emitted from different points in the transducer.
- Huygen's principle states however that an arbitrary wave form can be constructed from a large number of simple spherical waves of same frequencies. Every wave surface can then be visualized as an envelope of such elementary waves whose origin is located on a preceding wave surface.
- Consider the two extreme points at a "line" transducer, draw from each point half a circle in the direction of wave propagation of radius equal to the wave length with centre at the point, draw a tangent of the two semicircles parallel to the transducer (i.e. line connecting two extreme points), this line represents the wave surface (front), now draw two more semicircles with radius twice the wavelength, the intersection points of these new semicircles with the previous wave front represent points on the envelope of the net combined wave emerging from the transducer, repeat the above process a few times and you will see that these envelope points converge to a single point at which the wave front becomes a plane, giving rise to a plane wave.
- The region before the convergence of the envelop points represents the *near field*, and when the plane wave is formed one is in the *far field*.
- A typical transducer emits pulses lasting about  $1 \mu\text{s}$ , then detects the reflected signal perhaps  $0.1 \mu\text{s}$  later. There is therefore a dead time during which reflections from the specimen are confused with the tail pulse of the initial pulse. This corresponds to a *dead zone*, i.e. thickness within the specimen which can be directly examined.
- Since ultrasonic waves are not generated with exactly the same frequency or the same initial phase shift, but with the nominal frequency within a band, wave interference occurs within the near field resulting

in erratic changes in the wave pressure, with the pressure varying from zero to  $2ZU_0$ , where  $U_0$  is the velocity of the surface of the radiator (transducer),  $Z_0$  is the acoustic impedance of the medium in which the wave is travelling.

- The near field length is defined by:

$$N = \frac{d^2 - \lambda^2}{4\lambda} \approx \frac{d^2}{4\lambda} \quad (2.30)$$

where  $d$  is the probe's diameter, and  $\lambda$  is the wavelength.

- In the far field, the pressure decays smoothly such that:

$$P_z = \frac{\pi}{4} Z_0 U_0 \frac{d/\lambda}{z/d} \quad (2.31)$$

where  $z$  designates a distance on the axis normal to the surface of the probe. Note that larger probe diameters and higher frequencies result in higher pressures.

- The acoustic pressure of the probe is also dependant on the angle away from the beam axis. The longitudinal wave emitted from the transducer is concentrated within an angle  $\Phi$  determined by direction of first minimum in diffraction pattern and can be determined from:

$$\Phi = 2 \sin^{-1} \left\{ 1.2 \times 10^{-3} \frac{C_1}{fd} \right\} \approx 2 \sin^{-1} \left\{ \frac{1.22\lambda}{d} \right\} \quad (2.32)$$

where  $C_1$  is the speed of the dilational wave in the load material in m/s,  $f$  is probe frequency in MHz, and  $d$  is probe diameter in mm. The use of a narrow beam, small  $\Phi$ , resulting in the so-called "search units".

- Within the angle  $\Phi$ , the constant pressure boundary moves toward the probe until a node is reached, creating the major lobe.
- Minor lobes also exist at larger angles due to the shear waves and the surface waves, but are of little concern in most NDT applications.

#### 2.4.6 Selecting Criteria

To choose a good transducer as a source and sensor, the following aspects should be considered:

1. Cost.
2. Material: ceramic, unless harsh environment (quartz).
3. Frequency: take into account test material, near filed size, required resolution.
4. Size: probe diameter affects divergence angle and near filed size.
5. Divergence angle: large divergence leads to exposure of wider area and vice versa. Divergence angle depends on size of transducer, frequency and speed of wave in material.
6. Angle of incidence: if not normal use a wedge. Note that only longitudinal waves are generated, but wedge can be used to created transverse wave as will be shown later.
7. Efficiency versus sensitivity.
8. Band width: small.
9. Flaw size  $\geq \lambda$ .
10. Penetration: lower frequency decreases chance of scattering (allowing larger penetration), but this comes at the expense of decreased resolution (ability to resolve closely spaced reflected signals).
11. Temperature: Curie temperature.

## 2.5 Indication

- Normal beam, single transducer (pulse echo).
- Normal beam, dual transducer (through transmission).
- Angle-beam, single transducer (pulse echo).
- Angle-beam, dual transducer (pitch-catch).

### 2.5.1 Normal Incidence

Uses a longitudinal wave that enters perpendicular to surface of specimen.

### Pulse Echo Technique

- Reflected signal is measured with same transducer (with a switch circuit) or two transducers located on the same side. This is the most common method.
- In addition to the main pulse (initial echo), subsequent echo appear separated by a time,  $t = 2x/C_l$ , where  $x$  is distance from probe to reflecting surface.
- In a flawless specimen a series of back echos, corresponding to the far end of the specimen appear, decreasing in intensity as the number of echo increase.
- Appearance of a premature reflection indicates a flaw. Position of signal determines flaw location, while amplitude is an indication of flaw size.

### Transmission Technique

- Uses two transducers located at opposite ends of specimen, one acts as a source and the other as a receiver; also called pitch-catch method.
- Sound wave is generated continuously and wave amplitude is measured, flaws cause reduction in amplitude.
- Typically used when no suitable reflection can be produced from flaws, such as in a highly dense medium, material with large grain size or when many surface irregularities exist.
- Also used for thin sheets where pulse echo is impractical due to the dead zone effect. It is also used for the inspection of composites for large flaws.

## 2.5.2 Angle Beam

### Single Probe

- Mode conversion, from longitudinal to transverse and vice versa, is used.
- Beam enters the specimen at an angle, with the help of a plastic wedge.
- Can be used for areas that are inaccessible to normal beam incidence.

- Angle of incidence is chosen greater than first critical angle to eliminate longitudinal wave in specimen.
- Inspection relies on transverse wave reflection; which does not necessarily require perfectly perpendicular surface.
- One obtains a strong reflected signal only when there is a surface normal to the transverse wave produced in the inspected object.
- Transverse wave is reflected back as a transverse wave within the object and is refracted as a longitudinal wave within the wedge for detection by the probe; therefore indication is obtained by comparing the return pulse to the incident pulse.
- When angle of incidence is equal to second critical angle, probe can be used for surface inspection using the resulting Rayleigh wave.

#### **Angle-Beam Dual Transducer**

- Two separate sending and receiving wedge probes are used, also called pitch-catch method.
- Requires access to one side of object only.
- Pulses appearing in between the initial echo and the rear-wall echo indicate the presence of a flaw.
- If incident wave is at first critical angle, a surface wave is also created and detected, providing another reference corresponding to the shortest distance between the probes; a flaw indication should appear downstream of this signal.
- Relative positioning of four indications (initial, surface, flaw and back) is used to determine flaw position.
- Method is called "crack-tip" method, since scattering from the tips of a crack can be used to determine the crack size.

#### **2.5.3 Scanning Techniques**

**A-scan:** 1-D data, one point at a time; display of time-of-flight data (depth) and intensity information is also available; most widely used, gives flaw type, depth and location.



**B-scan:** 2-D data, parallel set of A-scans; display of time-of-flight along a line on surface of test specimen.

**C-scan:** 3rd dimension added to 2-D scan by restricting the echoes to a particular time corresponding to a particular depth in the specimen; thus providing a plan view of the object with the horizontal and vertical positions of flaws indicated on the screen.

## 2.6 Interpretation and Applications

### 2.6.1 General

- Size of flaw depend on amplitude of signal, while location is determined from time-of-flight.
- Real boundaries produces multiple period signals, spurious signal do not.
- Fatigue cracks are planar in shape and have well-defined boundaries, producing sharp distinct echoes; brittle fracture cracks produce the opposite effect.
- In inclusions, slag, porosity and large grain structures, produce not-so-clean echoes; one might lose the rear-wall back echo signal due to scattering and the absence of a flat planar surface; loss of back echo may be a good indication that component has deteriorated.
- Press fits: gears, turbine disks, roller bearings, wheels, pulleys etc. interfaces generate an ultrasonic response but in a regular fashion; if probes moves in a circular fashion one obtains a reasonably steady appearance (while it it were a crack fatigue the indication will disappear at some direction); quality of fit depends on degree of energy transmission (signal amplitude).
- Bonding between dissimilar materials: a good bond will produce well focused echoes, while the echoes form a defective bond will be spread over a wide time-of-flight range.
- False at-angle-reflections may appear at fillets on machined shafts.

### 2.6.2 Examination of Welds

- An angle beam is used, the distance at which it arrives at back surface is called the half-skip distance.
- The position of the first node, at full-skip distance, and the second node, twice full-skip distance, is determined using a second angular transducer as a detector, enabling the skip distance to be determined.
- Welds are examined by displacing the transducer from the half-skip to the full-skip distance.
- A good weld will give a sharp signal pulse a little after the half-skip position, as the wave has to travel some distance to the weld tip (root bead) before being reflected.
- A poor weld, with lack of complete fusion on the side nearest the transducer, signal will be received before the half-skip position, and on moving the probe the signal will move toward the half-skip position.
- The presence of an inclusion in the root bead will result in a signal that becomes a maximum when the probe is at less than the half-skip distance, as inclusion creates an acoustic impedance mismatch.
- Cracks and inclusions at other points in the weld will give indications as the probe moves from the half-skip to the full-skip position.
- Full-length scan of the weld can be obtained by moving the probe from the half-skip position to the full-skip position in a zigzag path along the centre-line of the weld.

### 2.6.3 Pipe Inspection

- An angular beam is used, as the probe moves toward and past a defect, the echo will rise and fall.
- If the probe is very close to the expected defect, the flaw echo may be masked by internal reflections in the wedge, but a dual probe technique can overcome this problem.
- Above can be done by placing the source transducer in one end of the wedge and the receiving transducer at the other end; resulting in an increase in the travel distance and hence better indication when the wedge is very close to the defect.

### 2.6.4 Surface Wave Inspection

- Surface waves are generated either by a longitudinal wave probe placed on the surface without coupling, or with a wedge probe such that the refracted shear wave is just past the second critical angle.
- Surface wave are reflected on surface anomalies and return to the transducer.
- Position of flaw can be obtained by tapping with a slightly oily finger in the travel path of the surface wave to cause the wave to be reflected back to the transducer, once the tapping passes the defect it will not affect the echo and the crack can be located.
- Surface waves are sensitive not only to defects but also to other surface anomalies such as pitting, oil, and other reflectors.
- Reflections occurring at curved surfaces, particularly sharp corners, cause difficulties in inspection.

### 2.6.5 Lamb Wave Inspection

- Used to inspect plates and sheets for anomalies caused by a change in section thickness.
- Thickness change will result in an excitation of different modes, affecting the dispersion characteristics of the wave.
- Used for examining laminations and corrosion in metal plates and delamination in composite materials.

## 2.7 Work Problems

1. Summarize in a table the definitions for the reflection coefficients for the amplitude, pressure and power at the surface of a longitudinal wave of normal incidence on an interface. Compare the values of these coefficients when:
  - (a) The acoustic impedances on both sides of the interface are equal.
  - (b) The wave is incident from a side of large acoustic impedance to air.

- (c) When the wave is incident from air on a surface of a large acoustic impedance.

Given the above results state the required criteria for good acoustic couplant and explain why such a couplant is needed.

2. An aluminium plate 50 mm thick is to be inspected ultrasonically using a normal beam probe. If the attenuation coefficient in the material is 85 dB/m, calculate the expected ratio of the pulse-echo heights of two successive pulses.
3. For the same frequency and the same material, shear waves are more attenuated than are longitudinal waves. Speculate on possible causes for this observed behaviour.
4. Probe ring-down time is an important performance characteristic. Discuss the probable ring-down characteristics of a lead zirconate titanate, PZT, ( $Z = 33.0 \times 10^6 \text{ kg/m}^2\text{s}$ ) as the piezoelectric transducer mounted on a plexiglas ( $Z = 3.218.8 \times 10^6 \text{ kg/m}^2\text{s}$ ) wedge, when:
  - (a) Air is the backing material.
  - (b) 200:100 tungsten/epoxy mixture is the backing material ( $9.4 \times 10^6 \text{ kg/m}^2\text{s}$ ).

It is suggested a minimum acoustic impedance of  $18.8 \times 10^6 \text{ kg/m}^2\text{s}$  be used as a backing material for PZT. How would this higher impedance material affect probe performance?

5. Calculate the first and second critical angle for a sound wave entering aluminium ( $C_l = 5090 \text{ m/s}$ ) from water ( $C_l = 1483 \text{ m/s}$ ).
6. Calculate the depth of near field and angle of beam spread of a 2 MHz longitudinal sound beam in aluminium ( $C_l = 6320 \text{ m/s}$ ) from a 25 mm diameter probe. What is the effect on both values of increasing the frequency to 2.25 MHz.
7. A lap joint between two sheets of copper ( $C_l = 3670 \text{ m/s}$ ,  $C_t = 4700 \text{ m/s}$ ,  $C_l = C_t = 2260 \text{ m/s}$ ,  $Z = 42 \times 10^6 \text{ Zkg/m}^2\text{s}$ ) of 10 mm thickness is to be made by brazing. Describe an ultrasonic technique that can be used to determine if the joint is completely filled, if the brazing thickness is 0.05 mm and the braze material is bronze ( $C_l = 3530 \text{ m/s}$ ,  $C_t = 4520 \text{ m/s}$ ,  $C_l = C_t = 2230 \text{ m/s}$ ,  $Z = 31 \times 10^6 \text{ Zkg/m}^2\text{s}$ ). Sketch the signal indication reporting the time-of-flight and relative height of

echoes, assume an attenuation coefficient of 100 dB/m for both copper and bronze.

## 2.8 Graphs

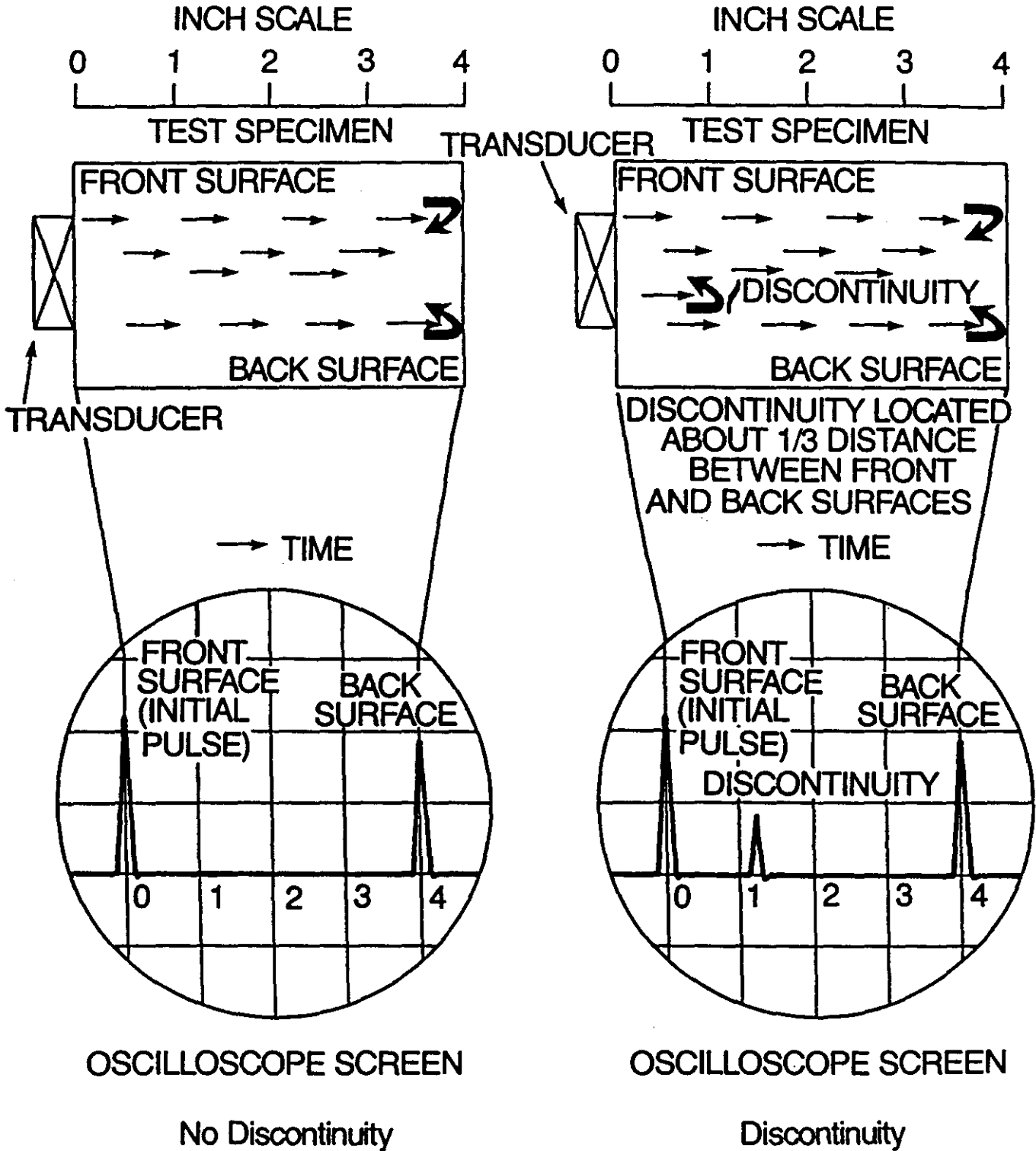

Figure 2.1: The Pulse Echo Technique

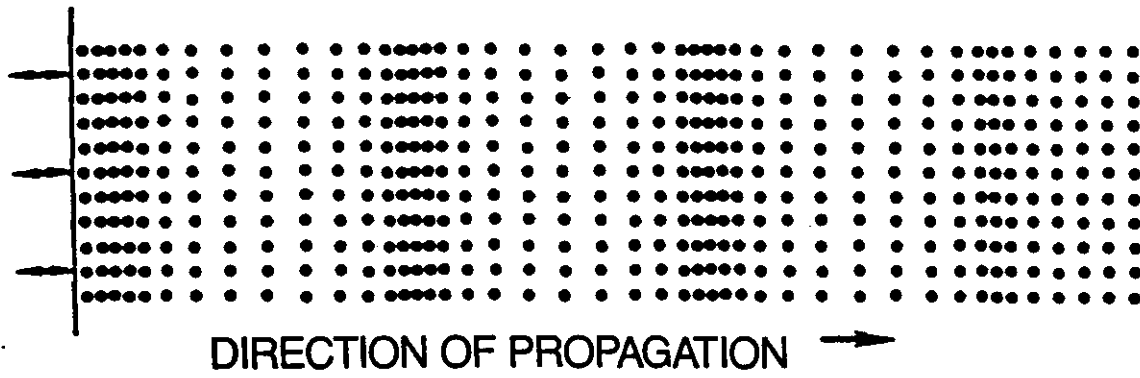

Figure 2.2: Longitudinal Wave

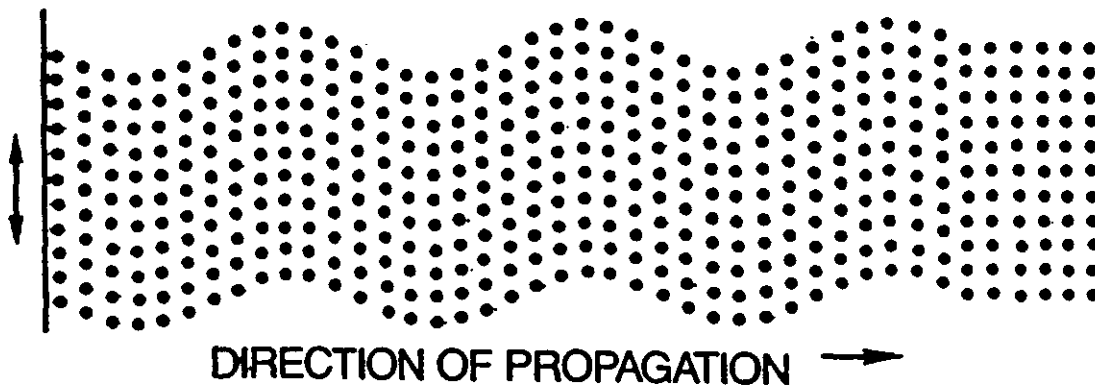

Figure 2.3: Transverse (Shear) Wave

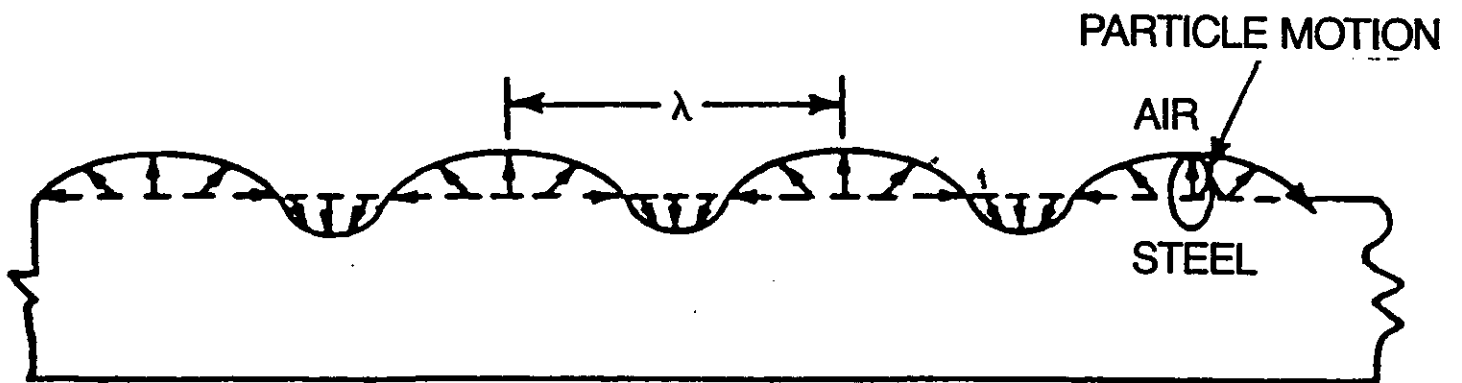

Figure 2.4: Rayleigh (Surface) Wave



ACOUSTIC PRESSURE (P),  
ARBITRARY UNITS

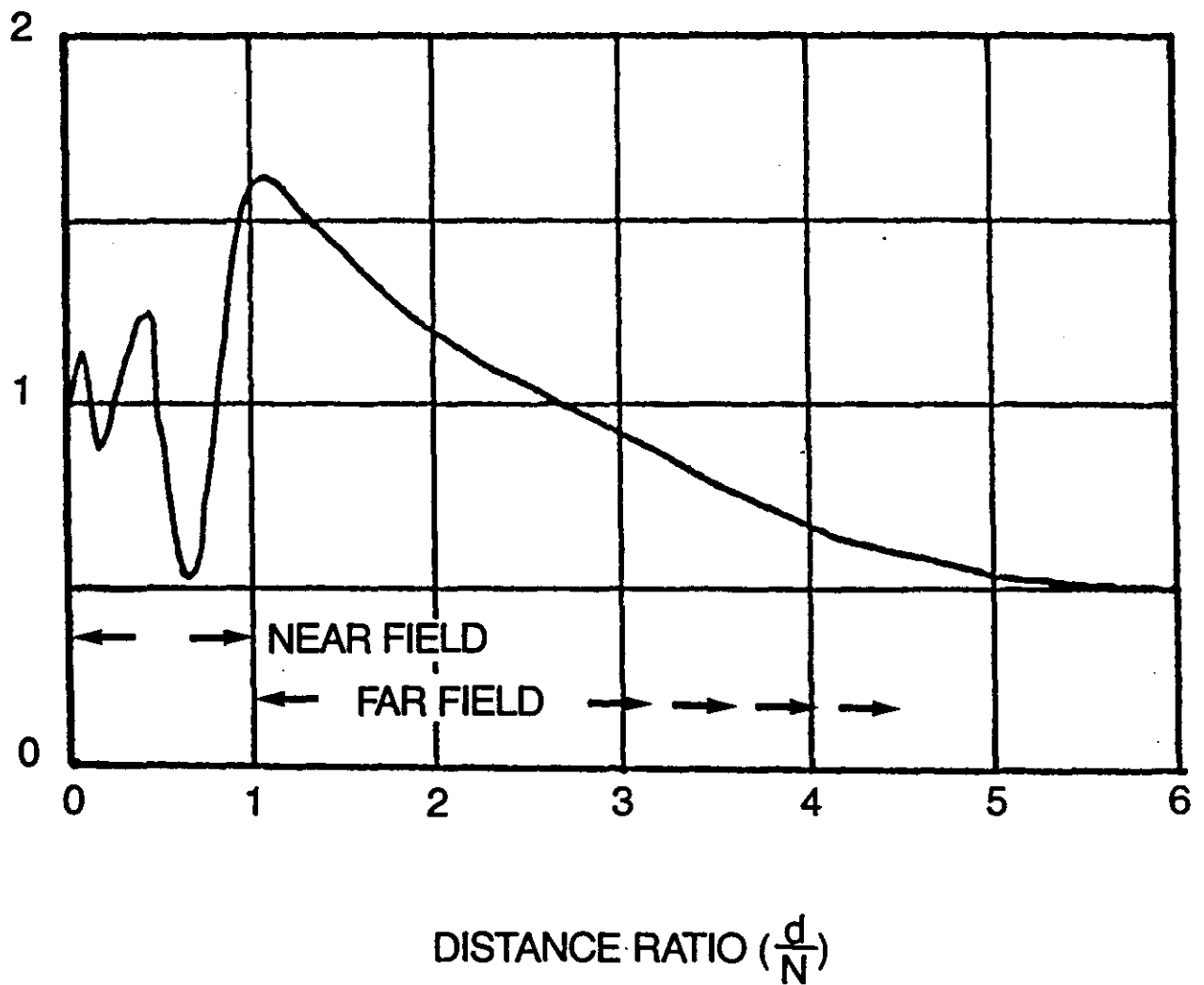

Figure 2.5: Near and Far Fields

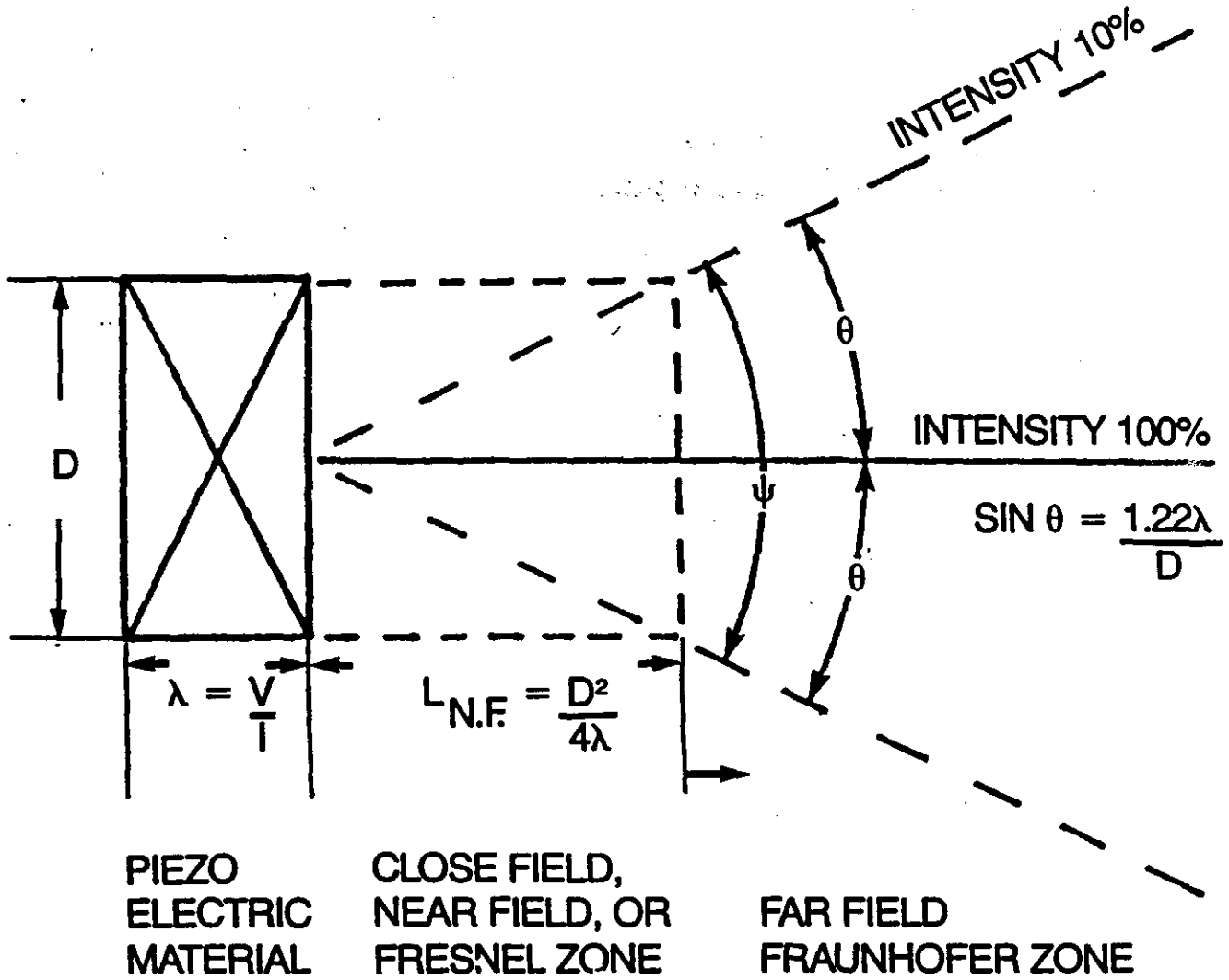
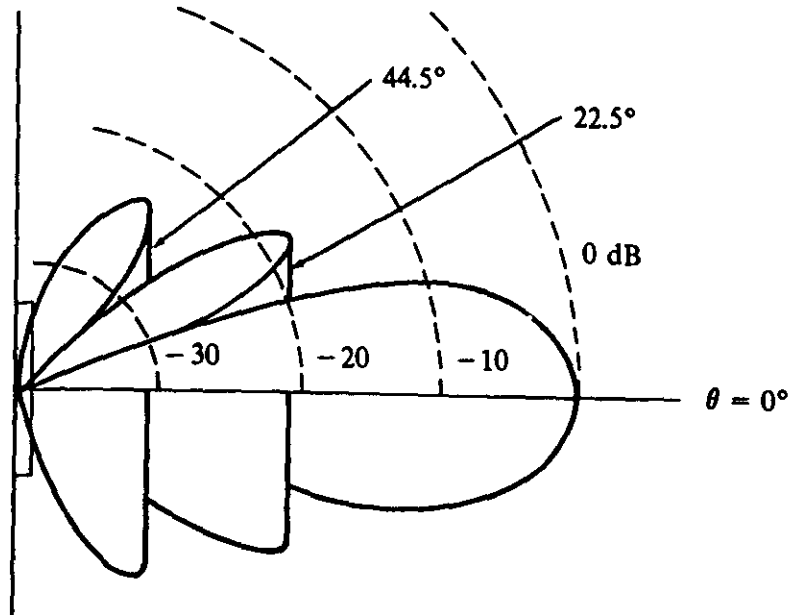
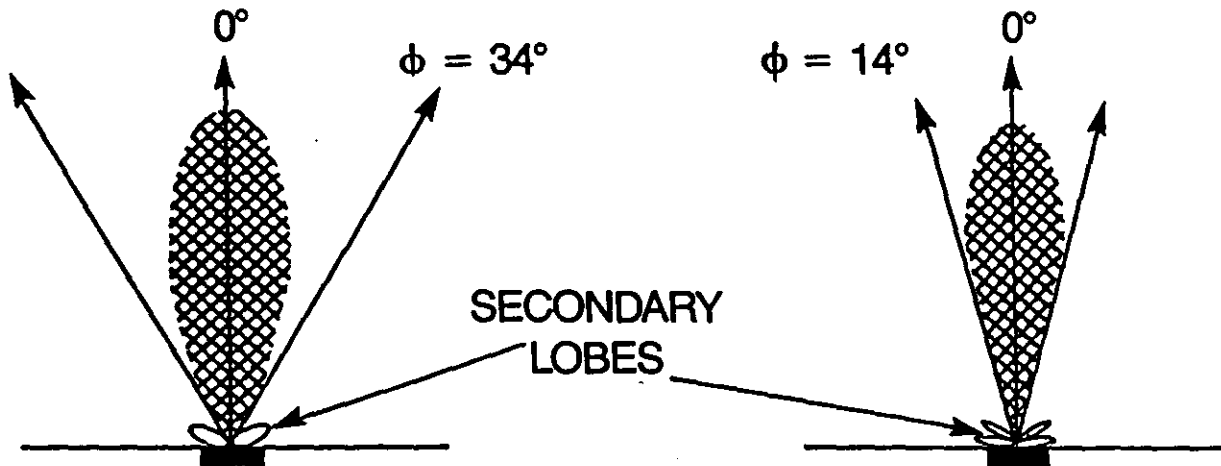

Figure 2.6: Beam Spread



$D$  = DIAMETER OF CRYSTAL

$\lambda$  = WAVE LENGTH OF ULTRASONIC WAVE IN STEEL



$F = 1.0 \text{ MC}$   
 $\lambda = 0.581 \text{ CM}$   
 $D = 1/2 \text{ INCH}$

$F = 2.25 \text{ MC}$   
 $\lambda = 0.259 \text{ CM}$   
 $D = 1/2 \text{ INCH}$

Figure 2.7: Beam Pattern, (top:  $\lambda = \pi d/5$ )

## PULSE ECHO TECHNIQUE

## SINGLE TRANSDUCER

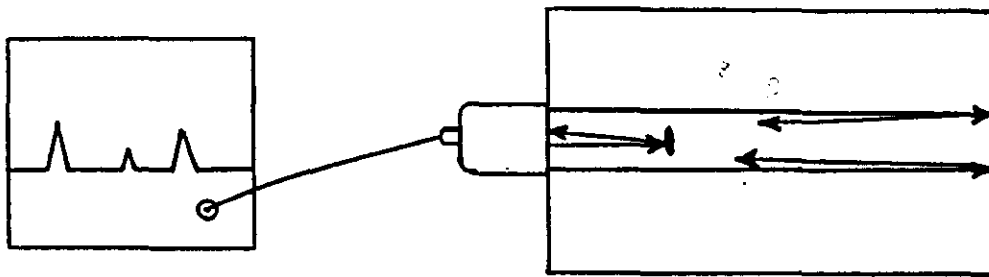

## DUAL TRANSDUCER

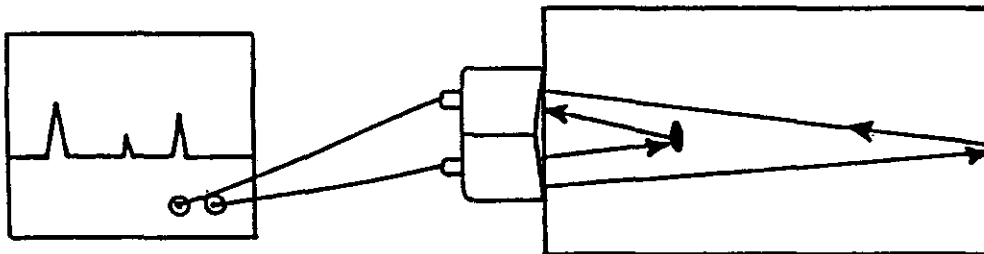

Figure 2.8: Normal Beam Techniques

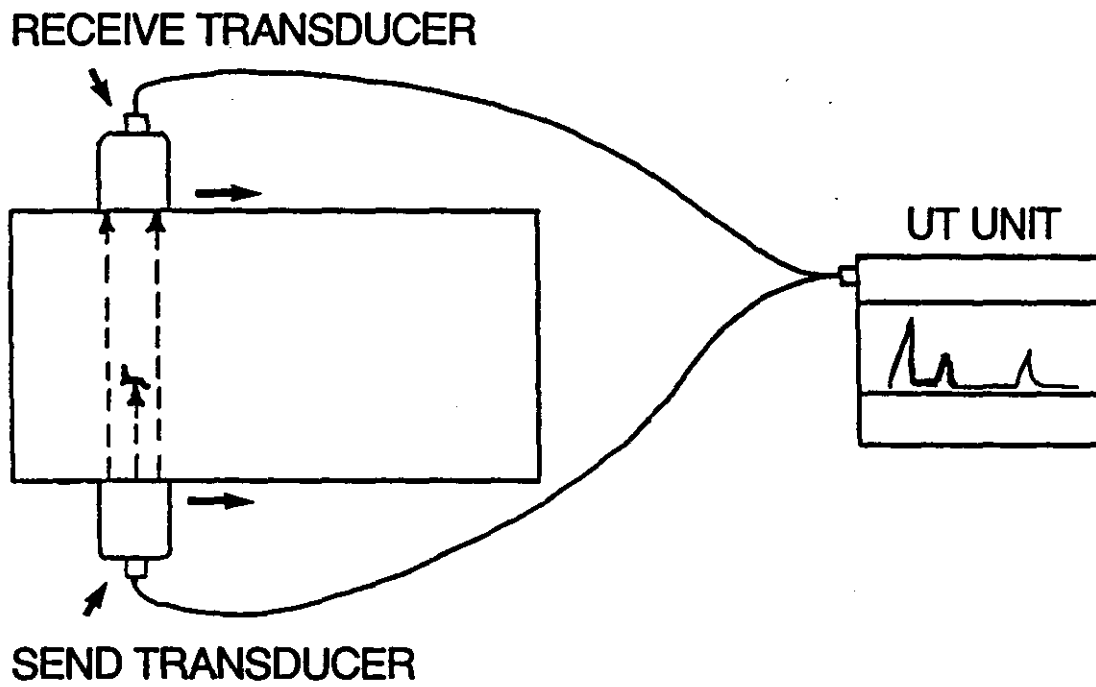

Figure 2.9: Transmission Technique

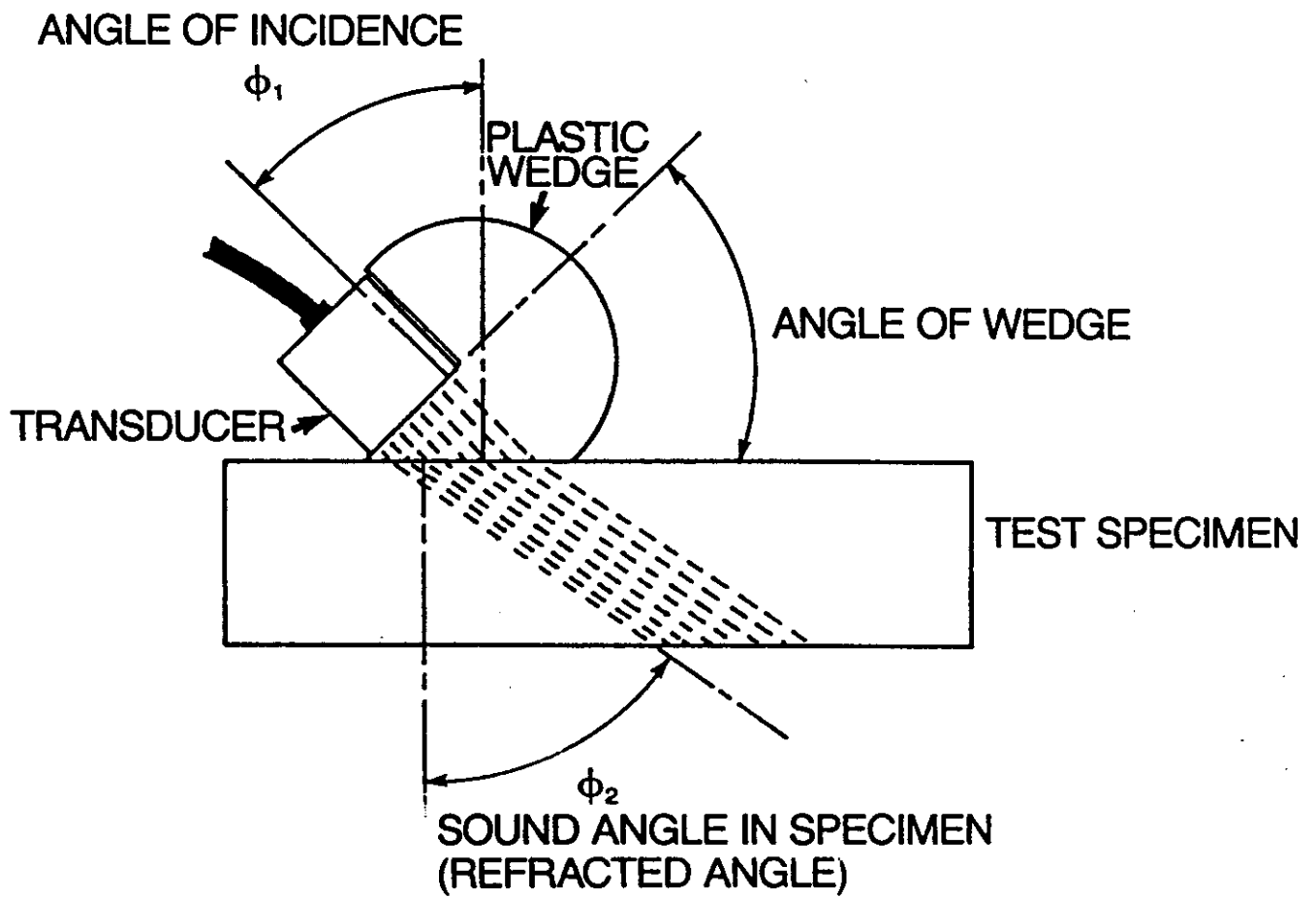
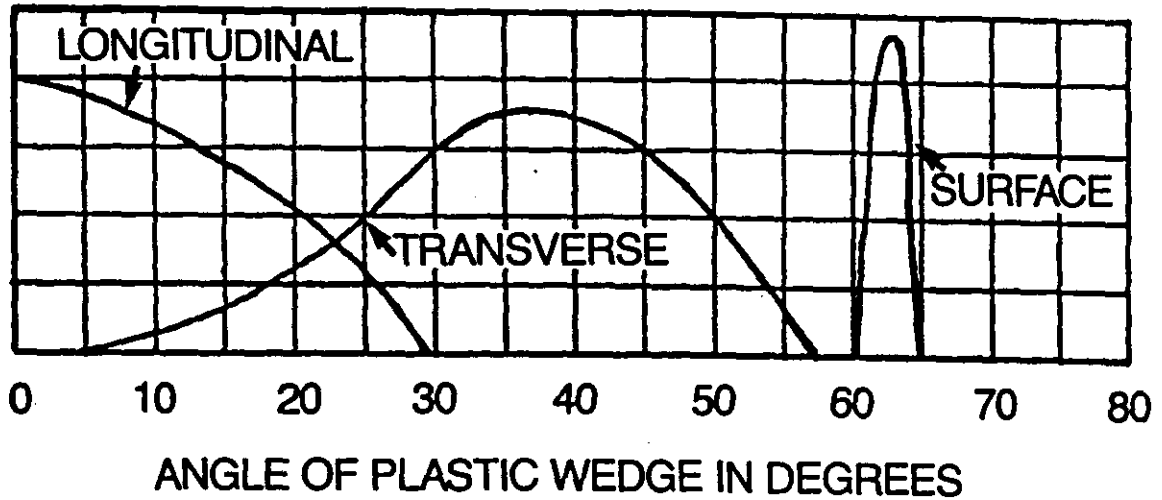

Figure 2.10: Angle Beam Technique

RELATIVE  
AMPLITUDE



ANGLE OF  
SOUND  
(DEGREES)

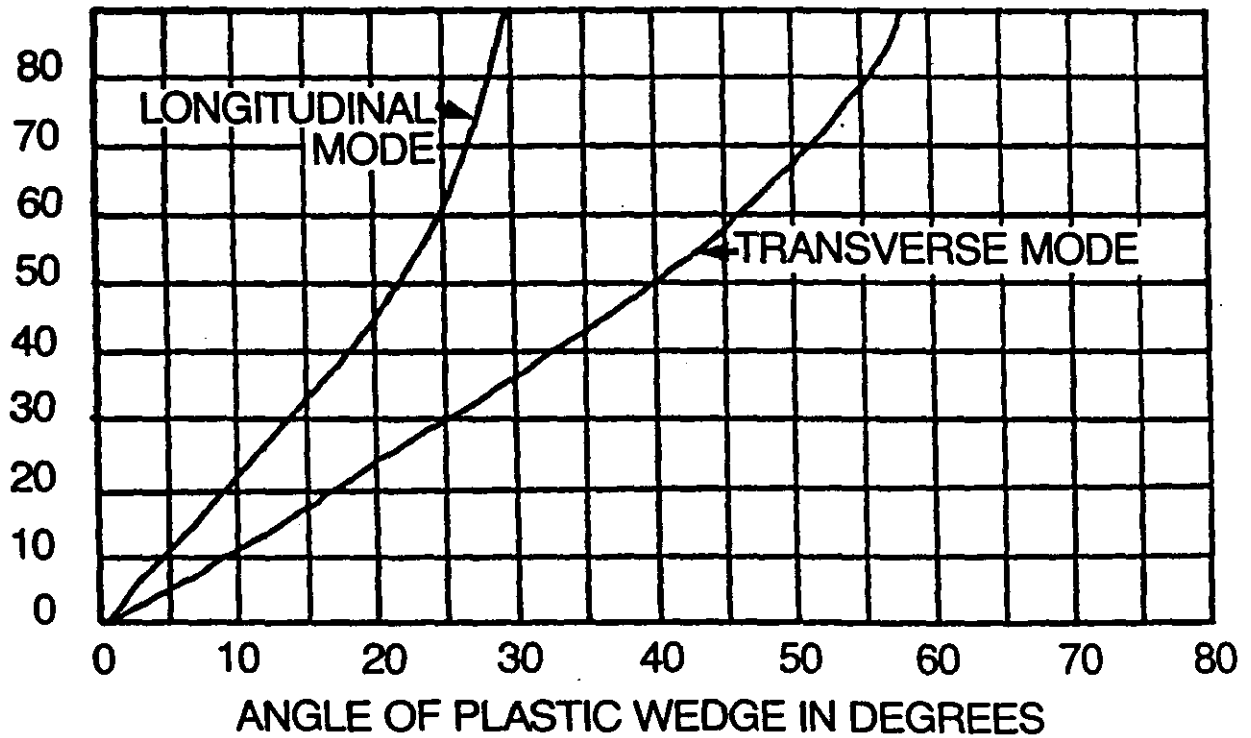
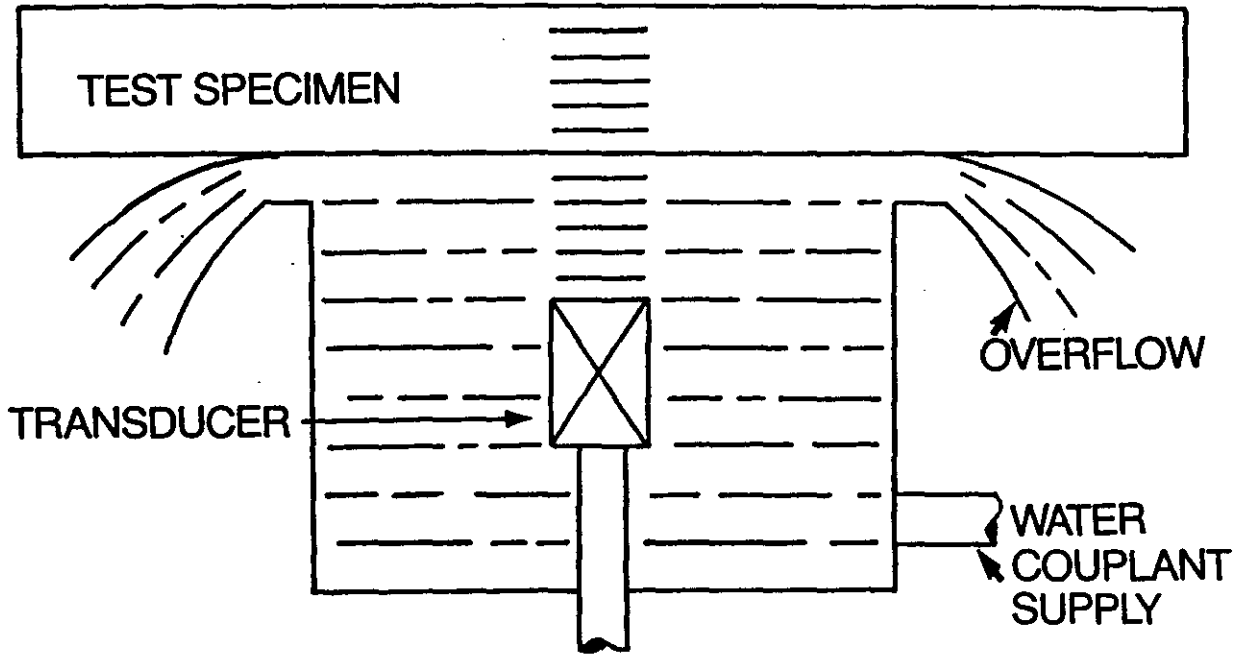

Figure 2.11: Longitudinal, Transverse and Surface Waves in a Wedge

BUBBLER TRANSDUCER TECHNIQUE



WHEEL TRANSDUCER TECHNIQUE

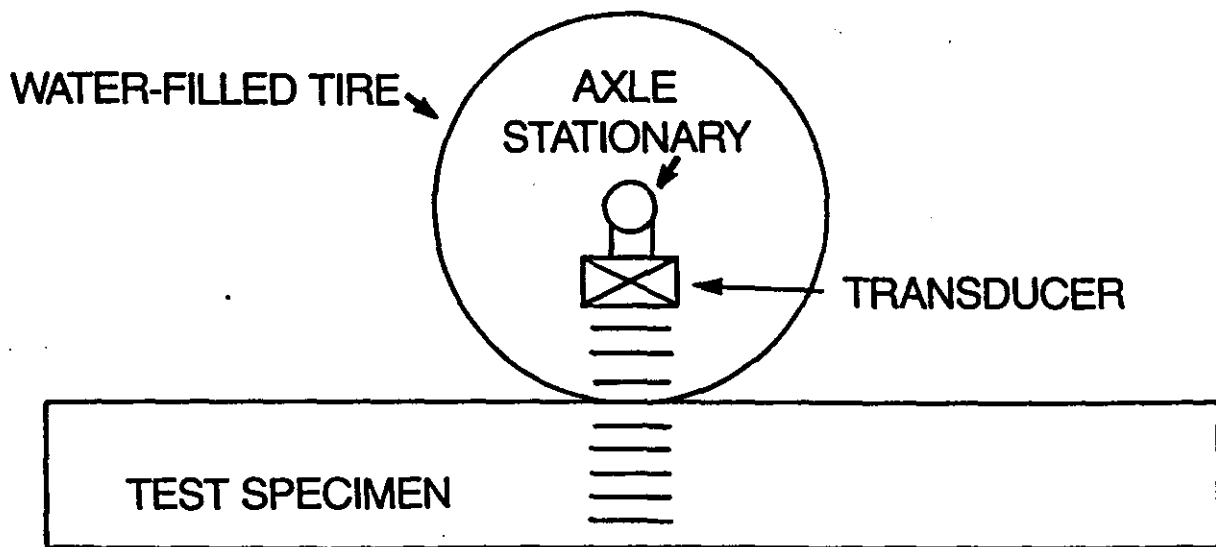

Figure 2.12: Bubbler and Wheel Techniques



### WATER PATH DISTANCE ADJUSTMENT

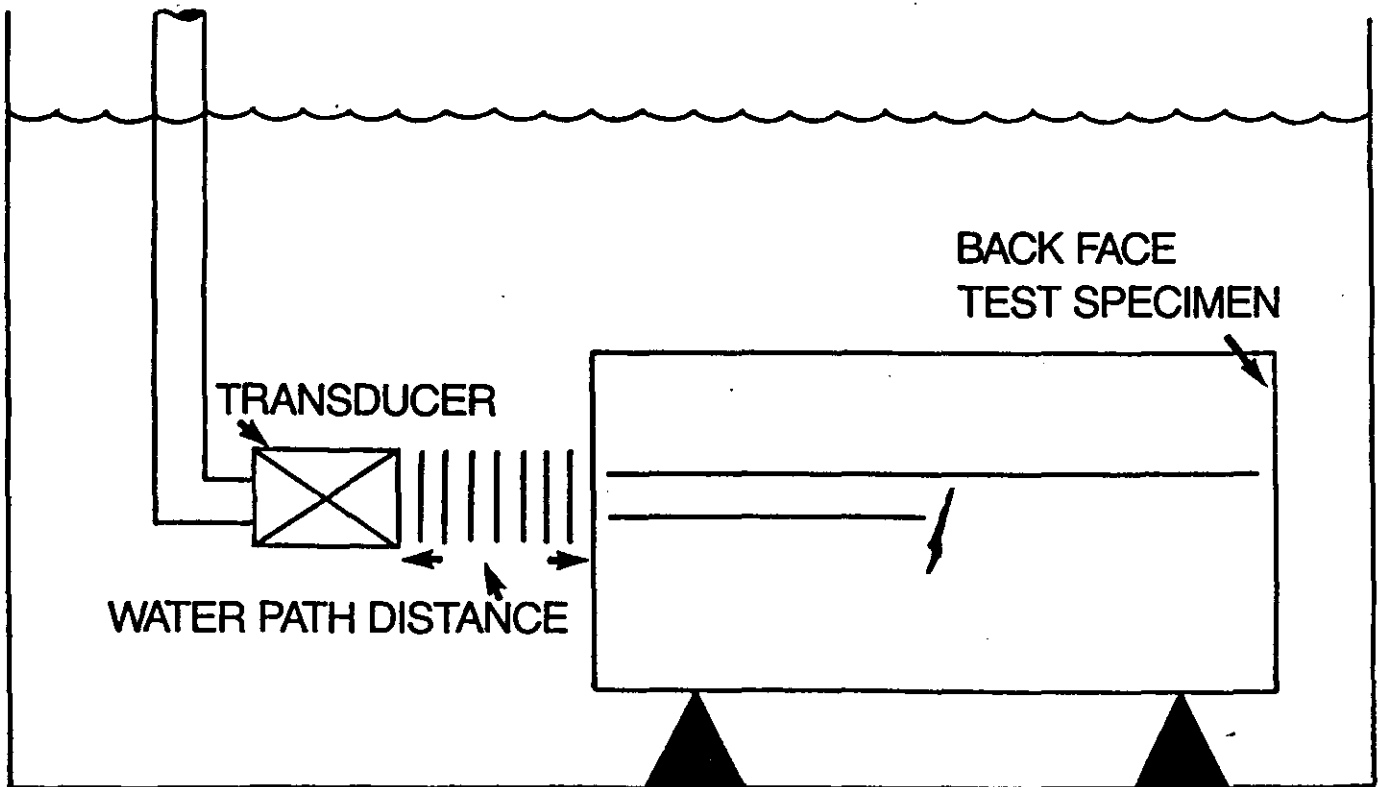
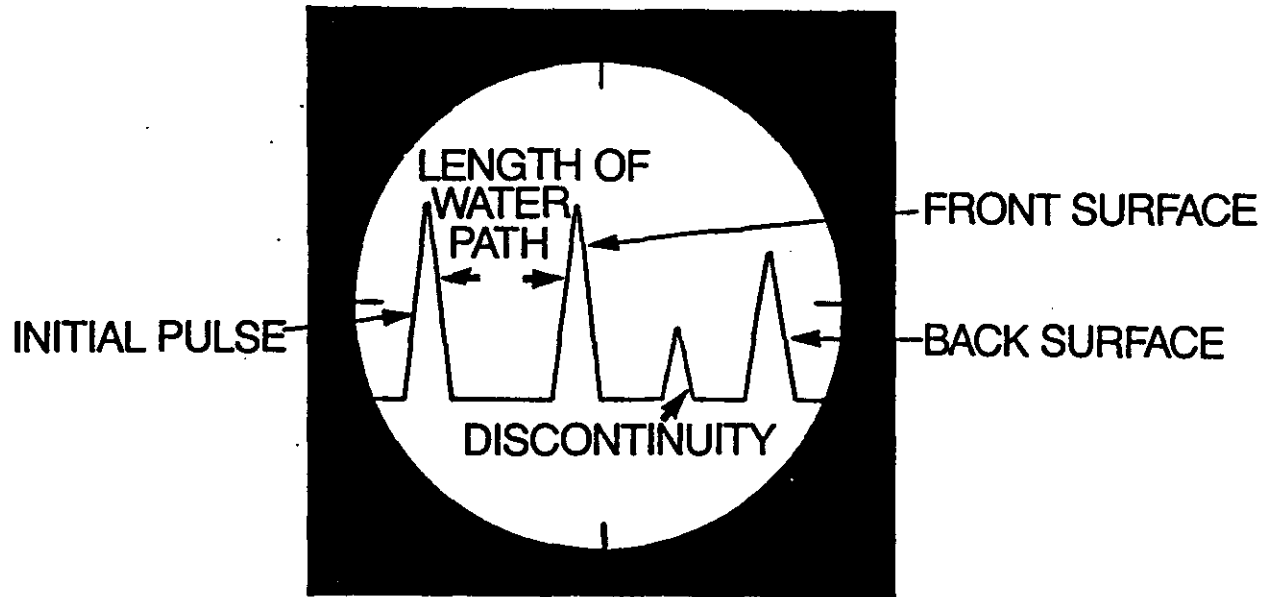

Figure 2.13: Water Immersion Technique

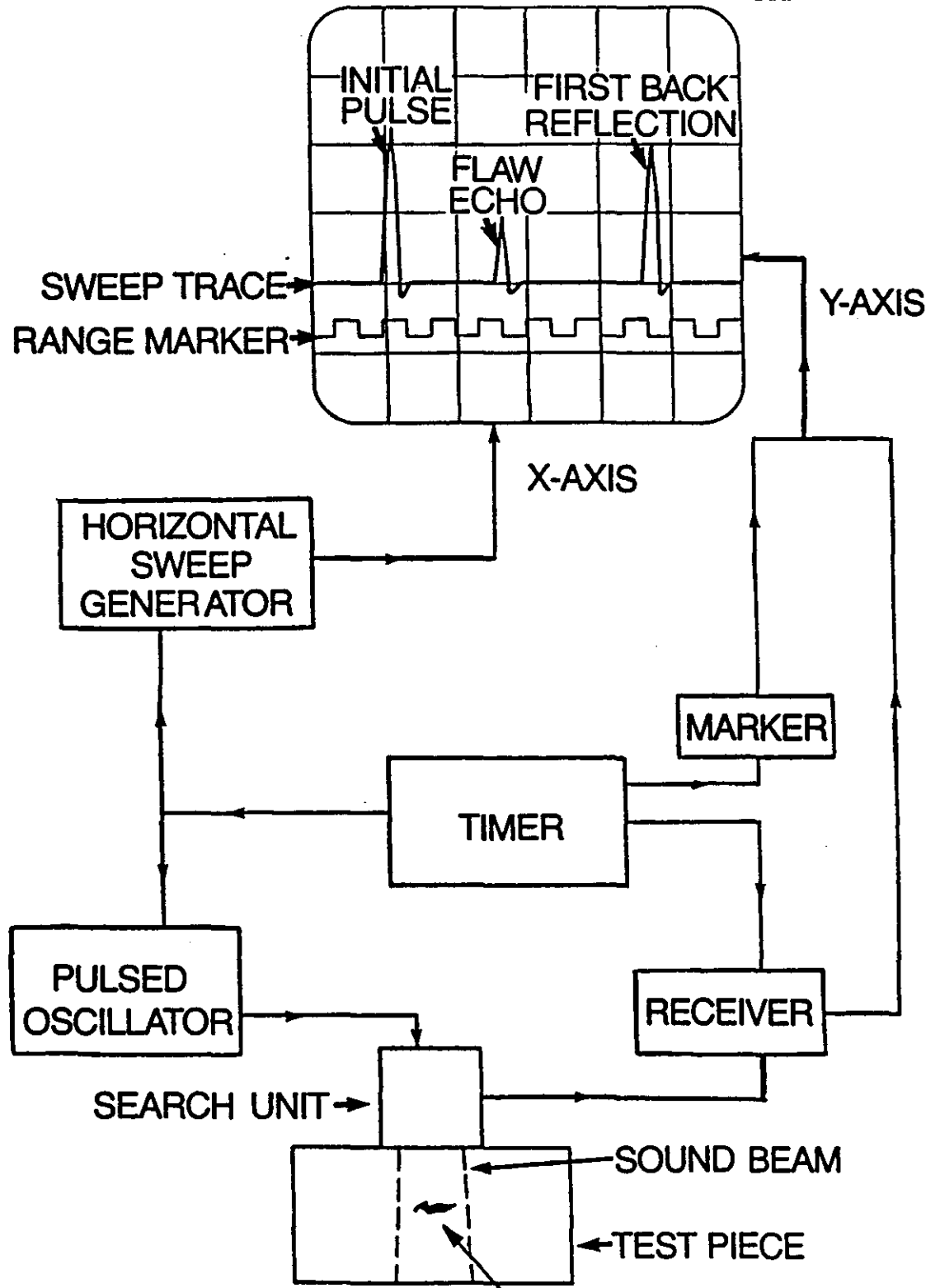

Figure 2.14: A-Scan FLAW

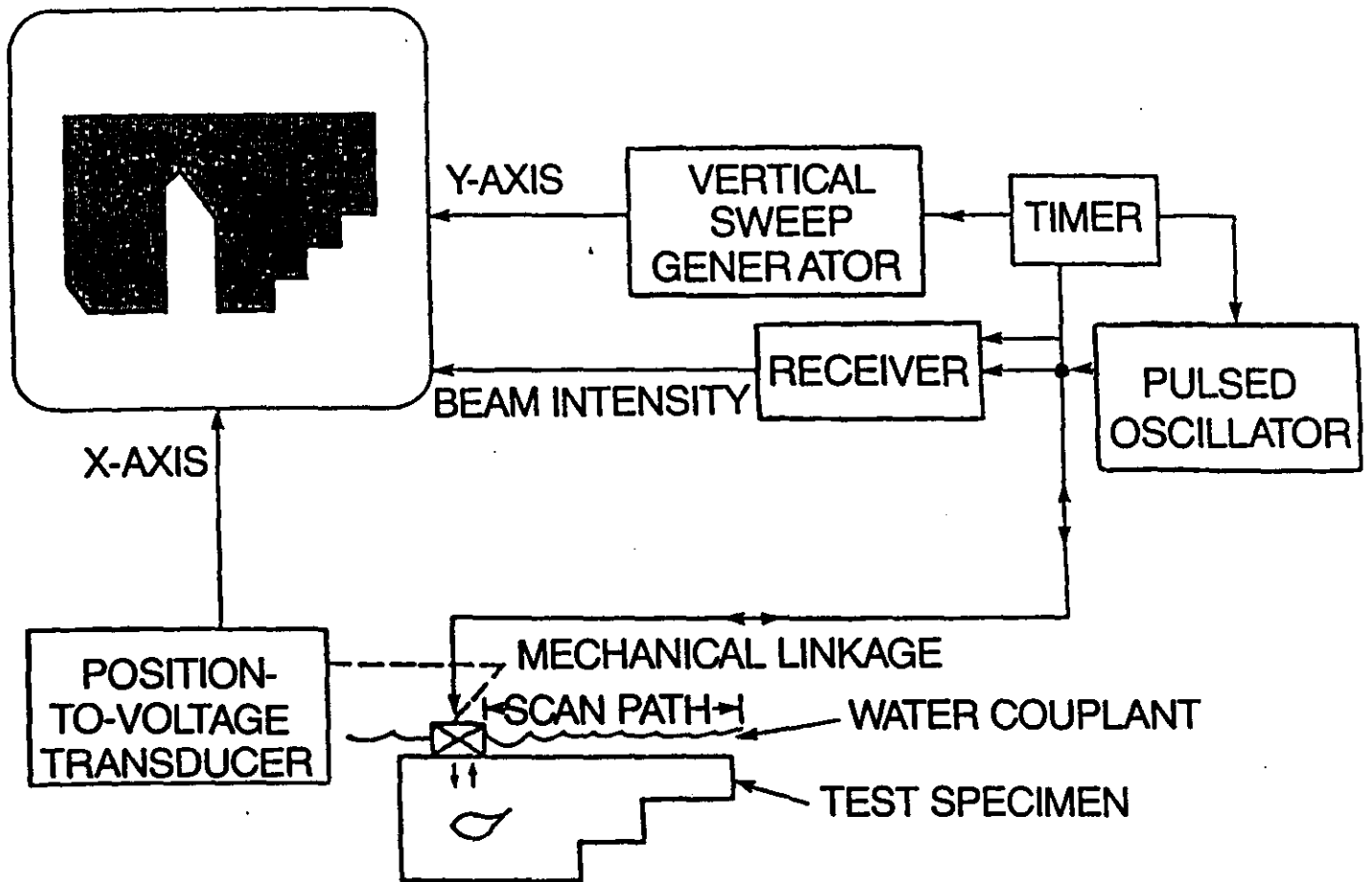

Figure 2.15: B-Scan

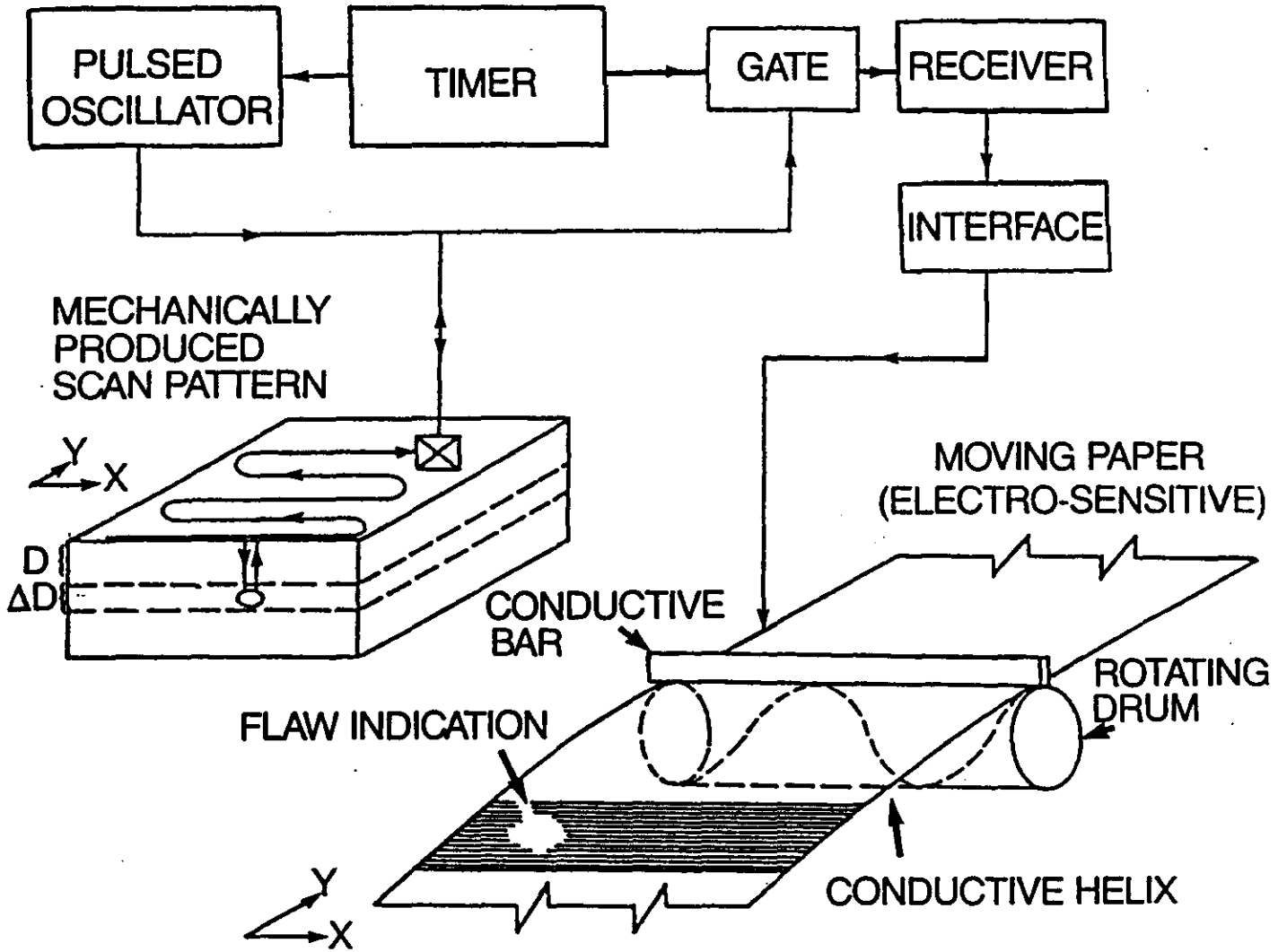

Figure 2.16: C-Scan

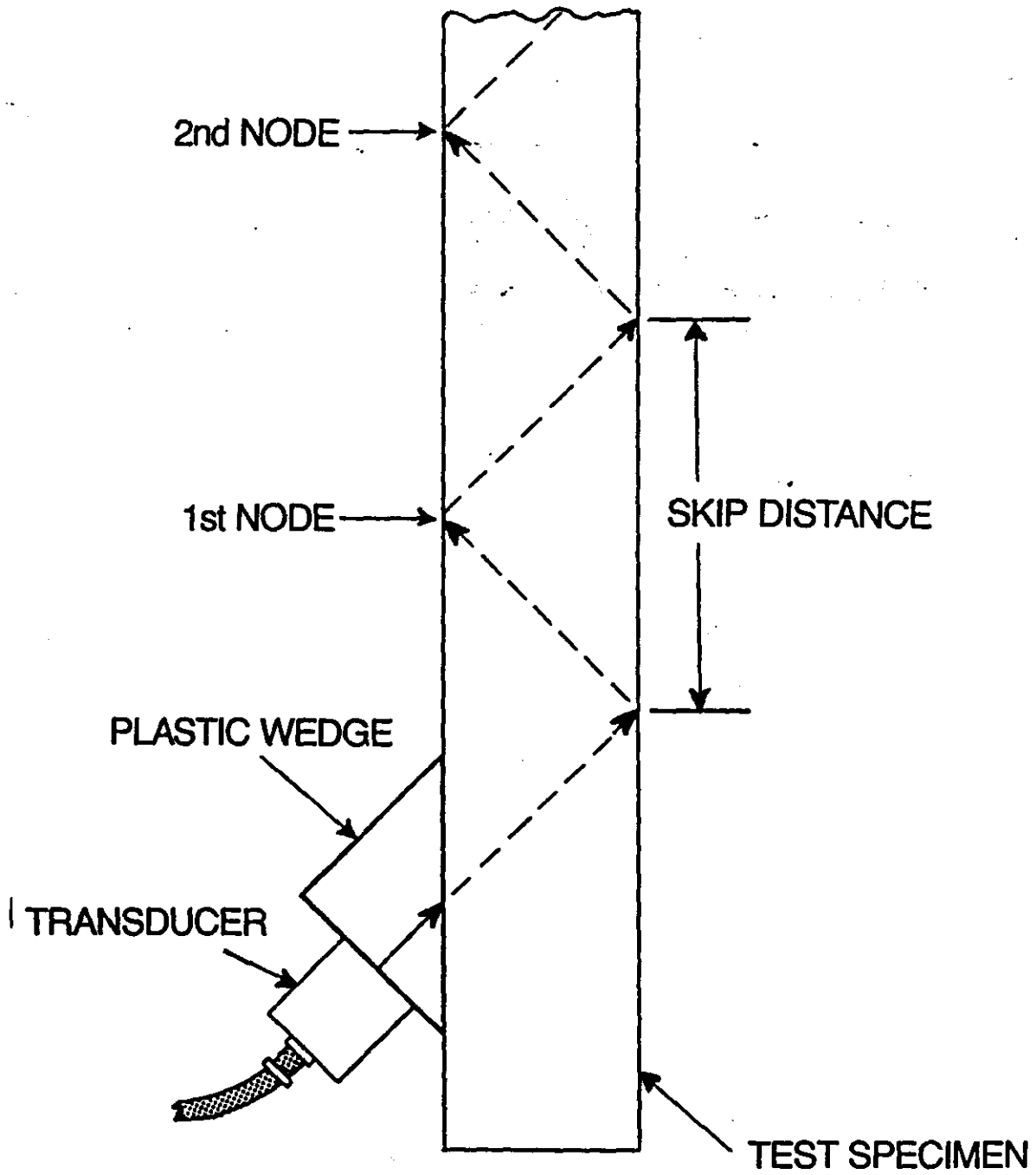

Figure 2.17: Nodes Technique

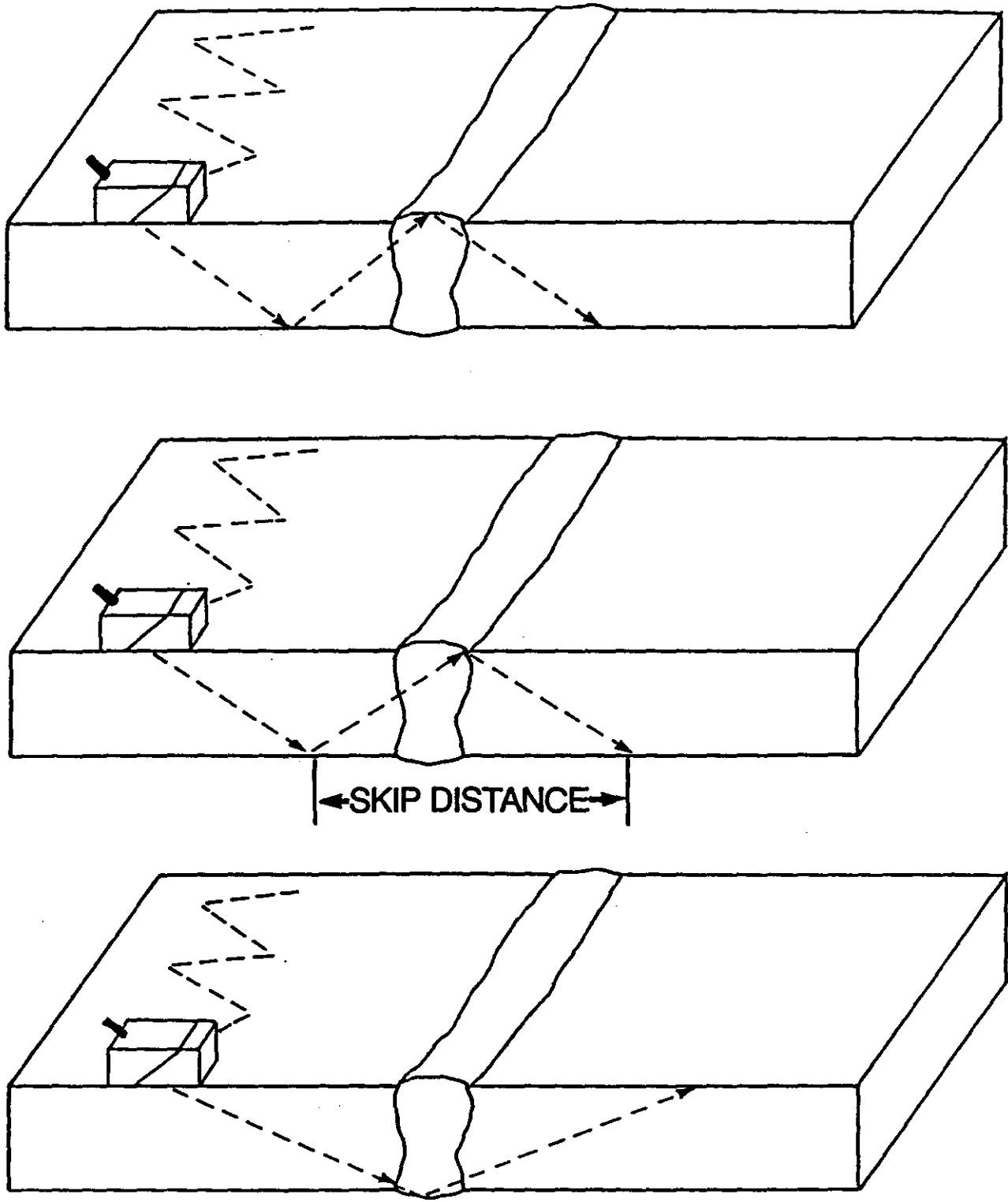
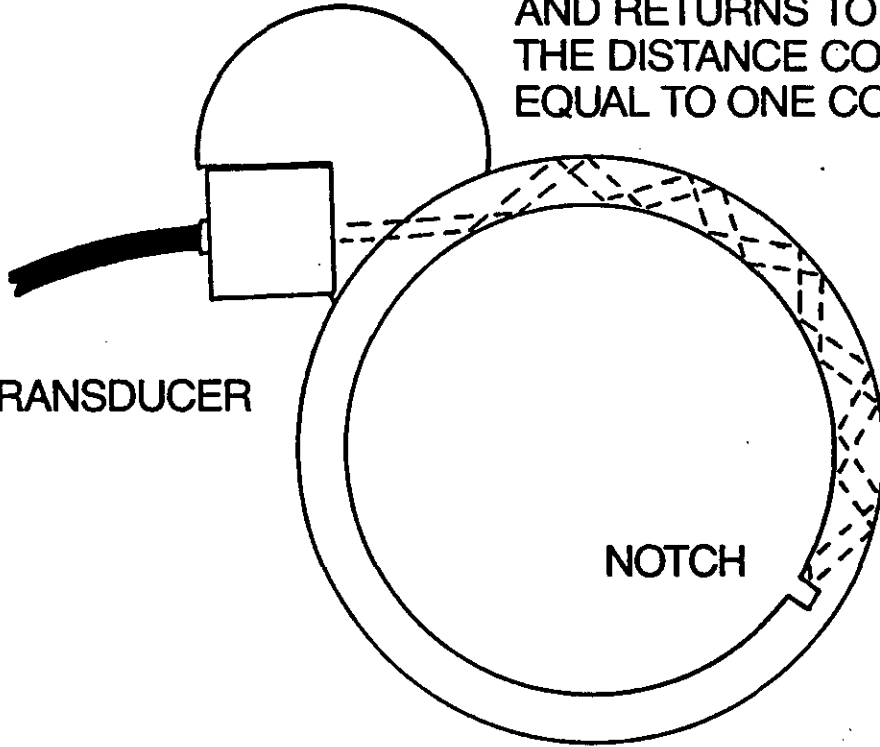

Figure 2.18: Weld Inspection with Node Technique

PLASTIC WEDGE

SOUND TRAVELS TO NOTCH 180°  
AND RETURNS TO SOURCE,  
THE DISTANCE COVERED IS  
EQUAL TO ONE COMPLETE REVOLUTION.

TRANSDUCER



NOTCH

CRT

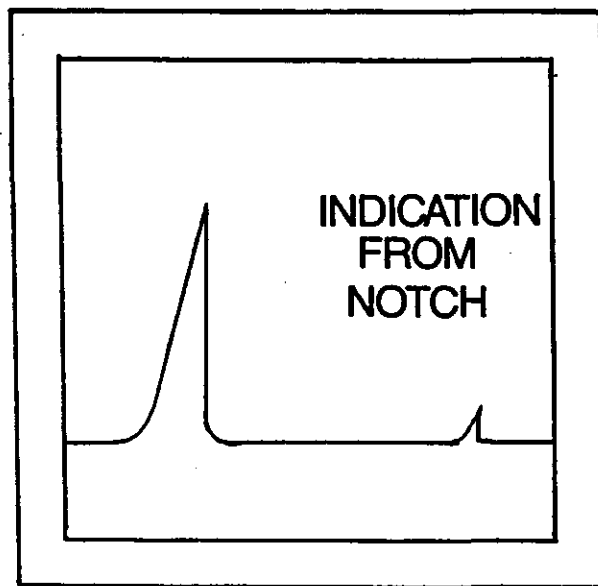

Figure 2.19: Pipe Inspection

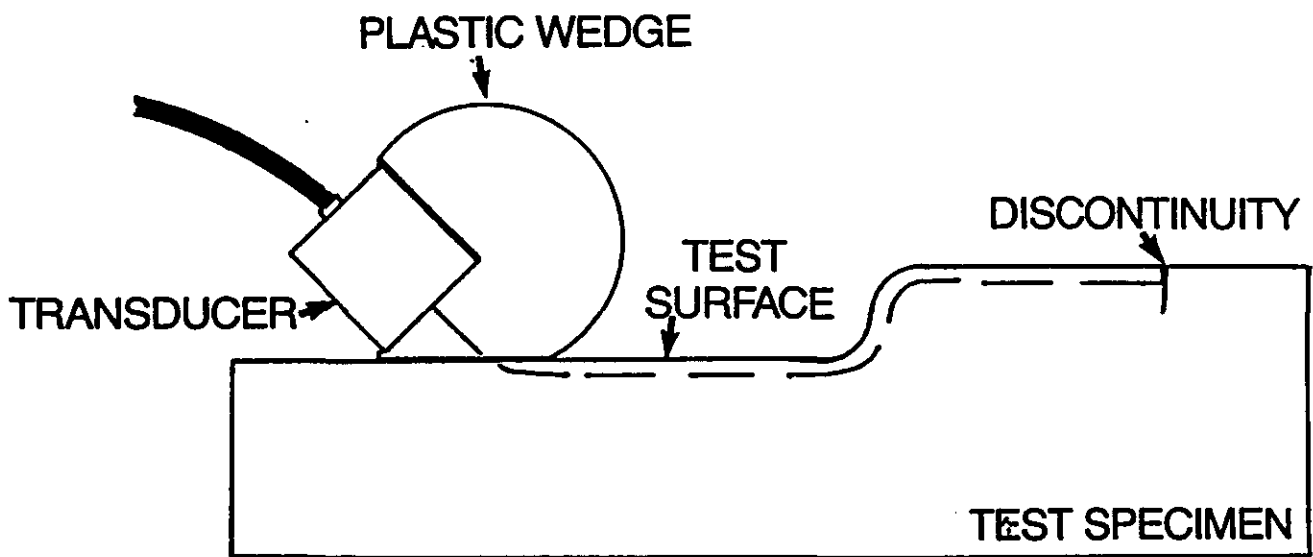

Figure 2.20: Surface Inspection